

Parts List				
ITEM	QTY	TITLE	PART NUMBER	DESCRIPTION
1	2	Brazen Altar - End	005	ABS/PC
2	2	Brazen Altar - Side	006	ABS/PC
3	1	Grate	007	ABS/PC
4	2	Carrying Pole - .25"	008	.25" x 14" Plastic Rod

PRESS FIT ASSEMBLY W/ BONDING AGENT

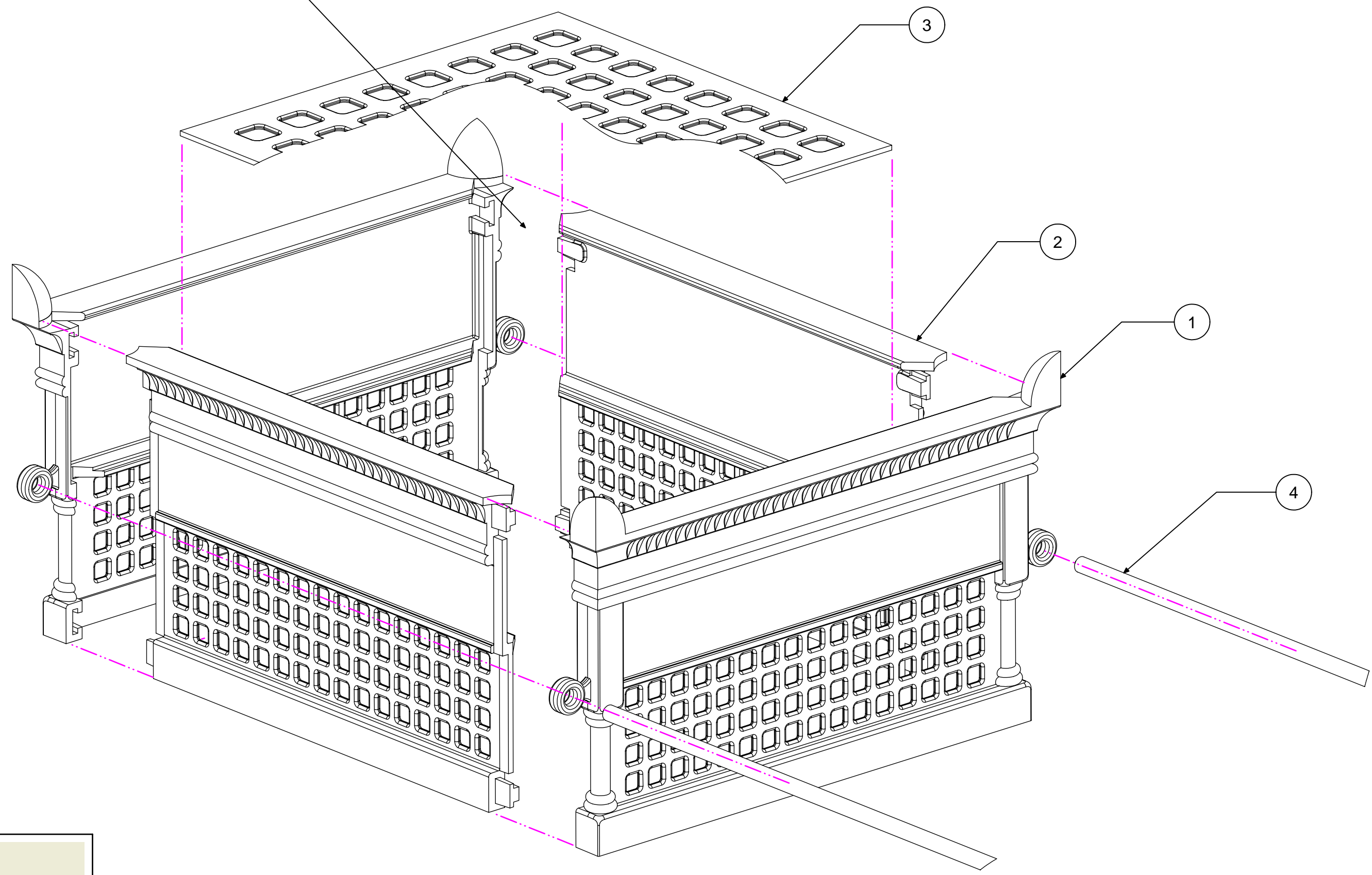

ALTERNATIVE SNAP-FIT ASSEMBLY

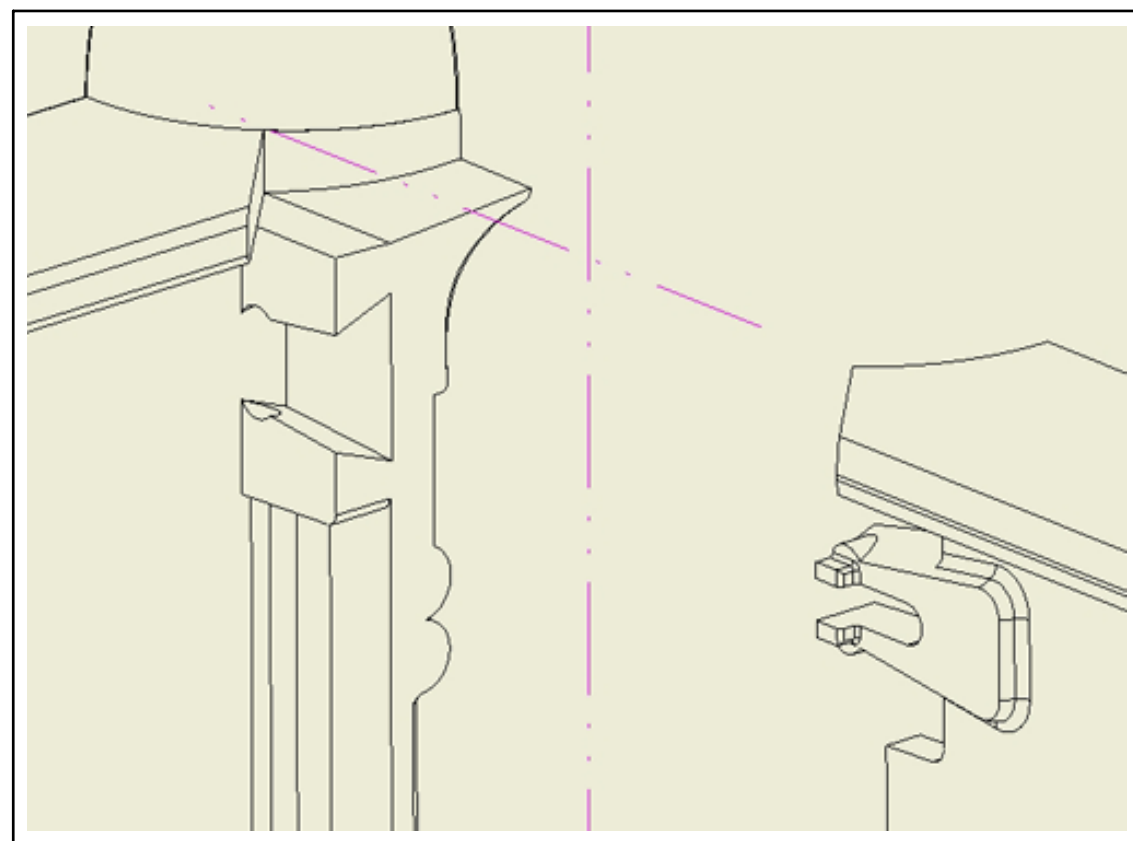

DRAWN ANDREW CROSS	3/17/2004	XYZED 3-D SOLUTIONS		
CHECKED		TITLE		
MFG		BRAZEN ALTAR - ASSEMBLY		
APPROVED		SIZE C	PART NO N/A	REV 7
www.xyzed.ca		SCALE 2:3	SHEET 1 OF 4	

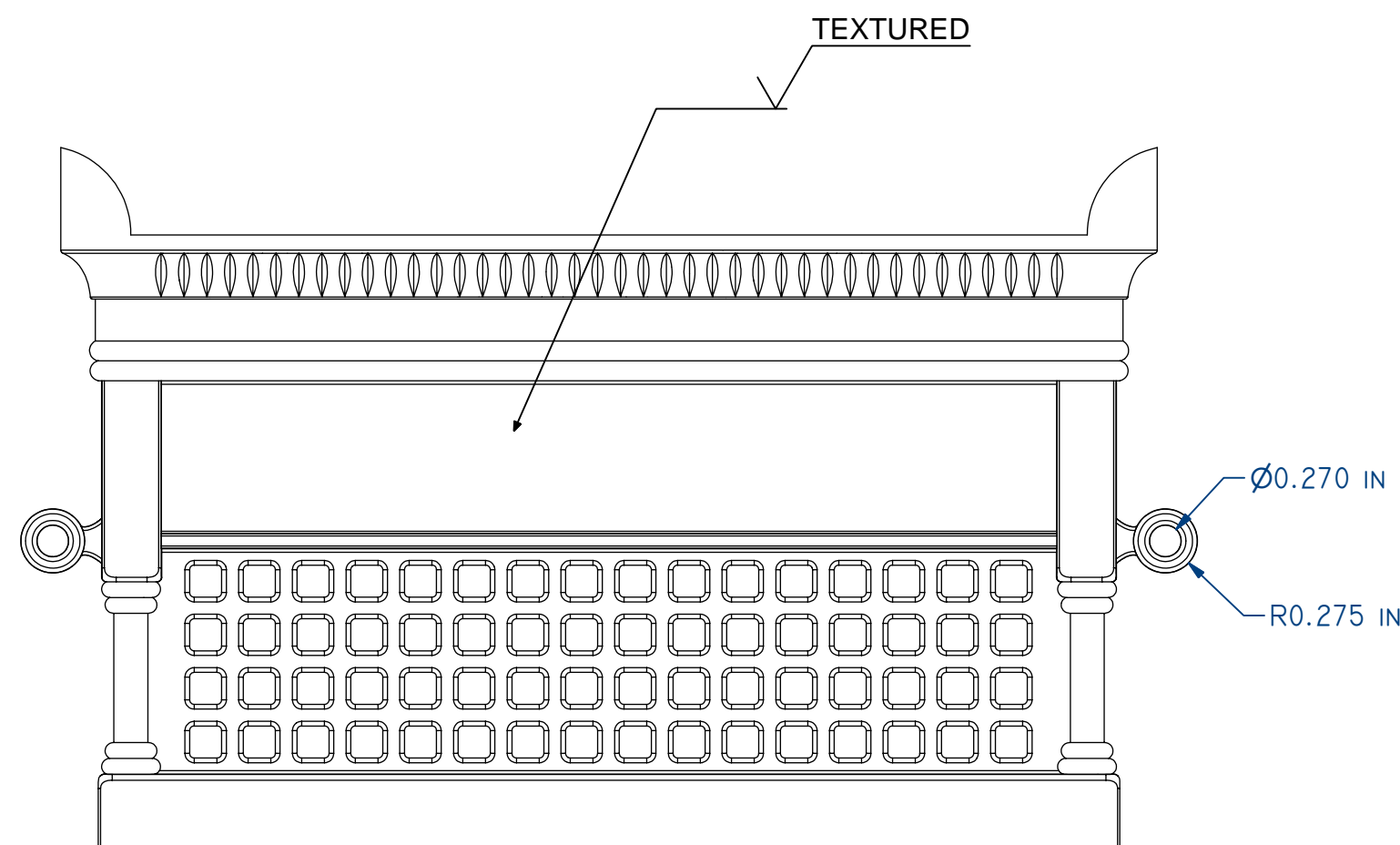
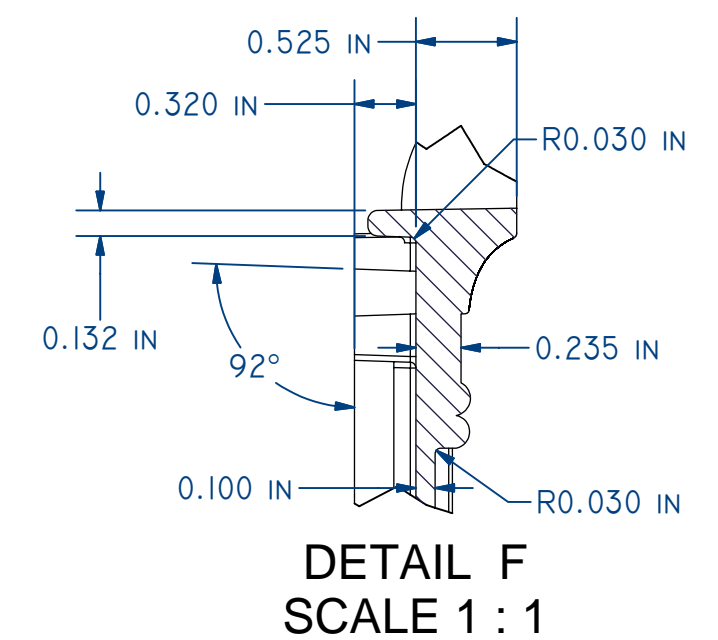
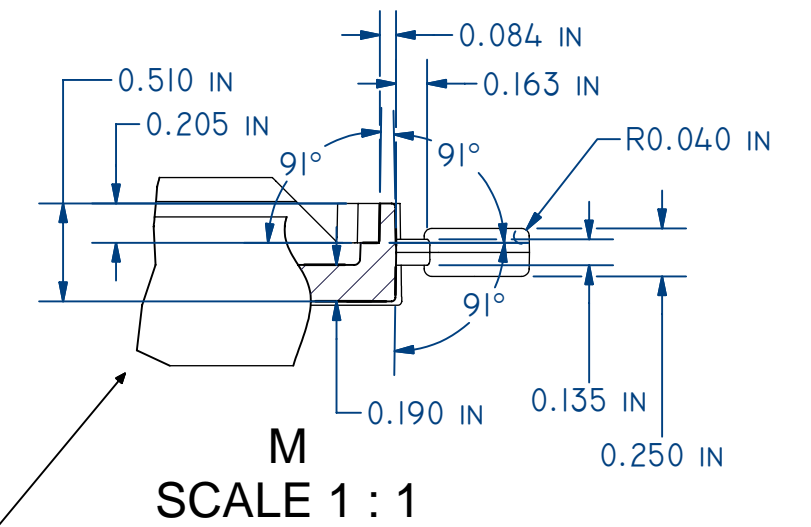
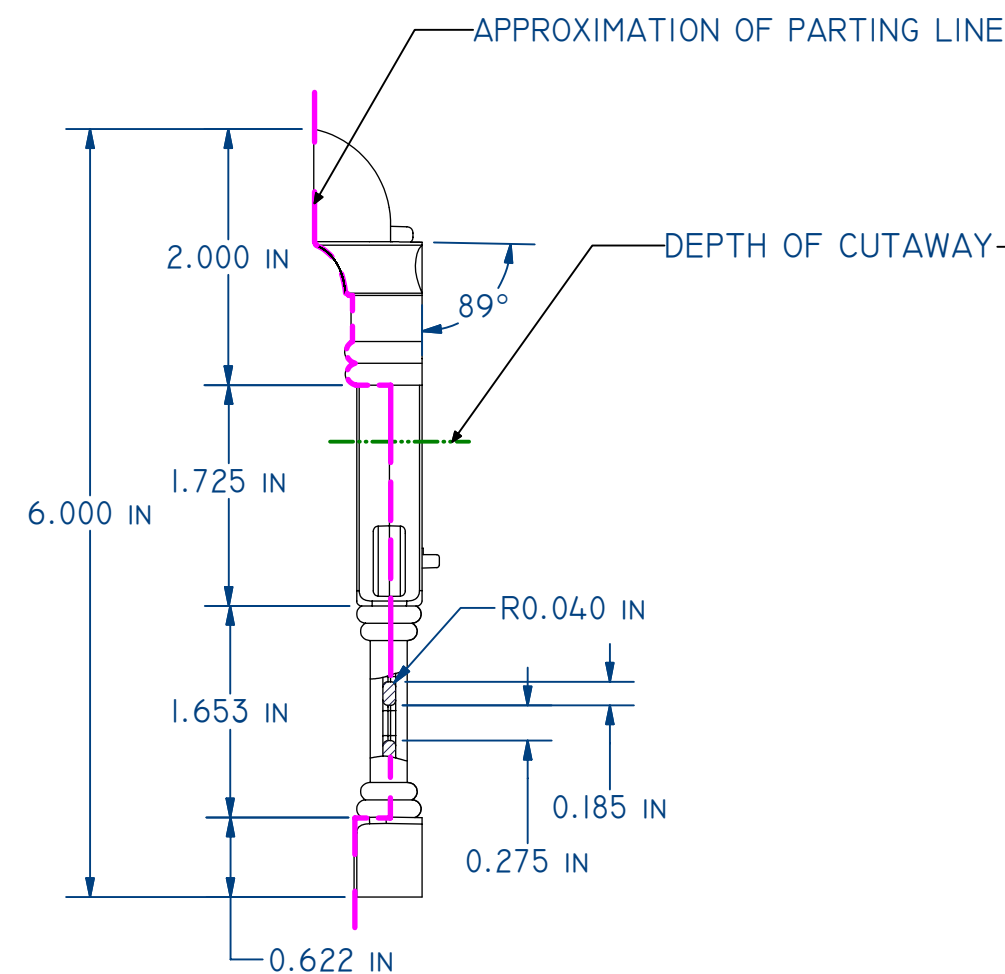
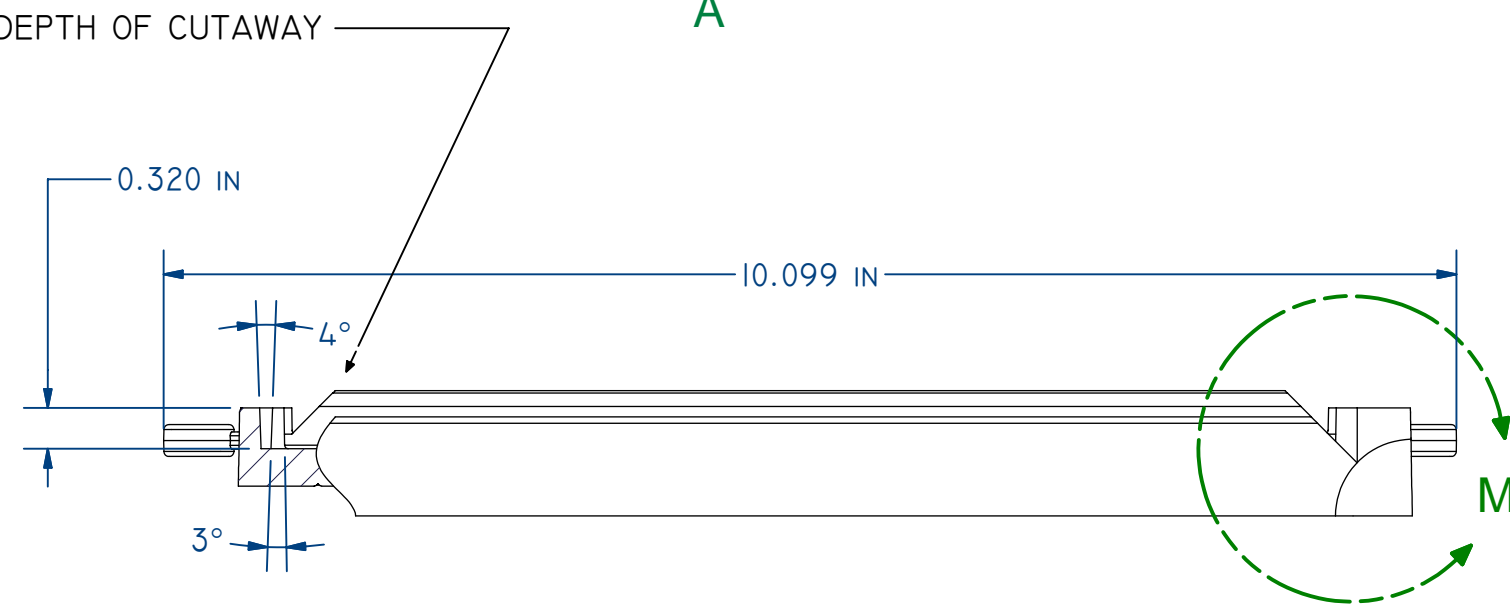
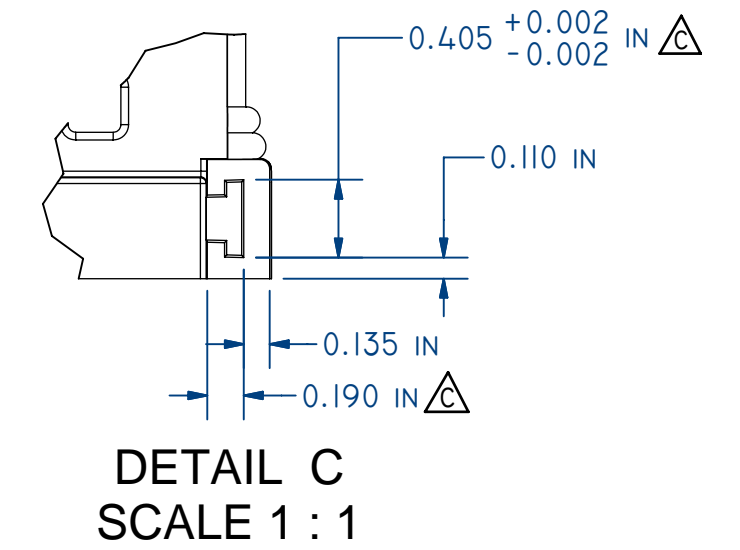
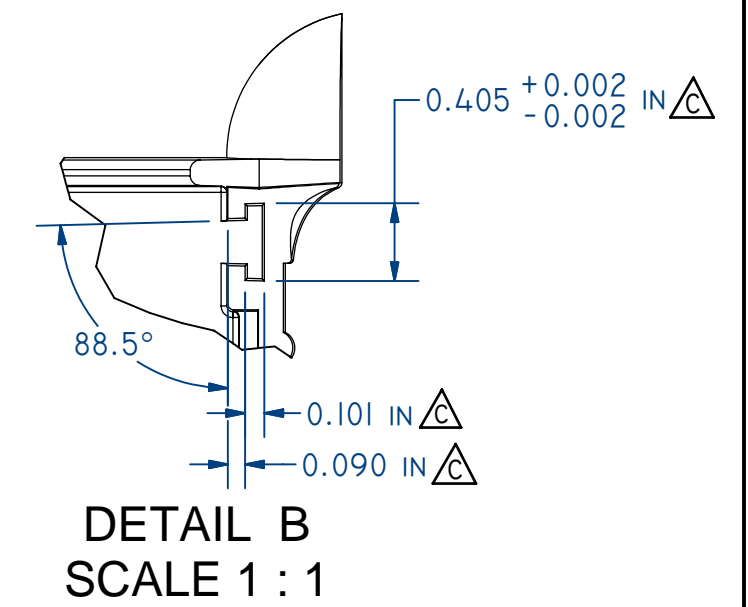
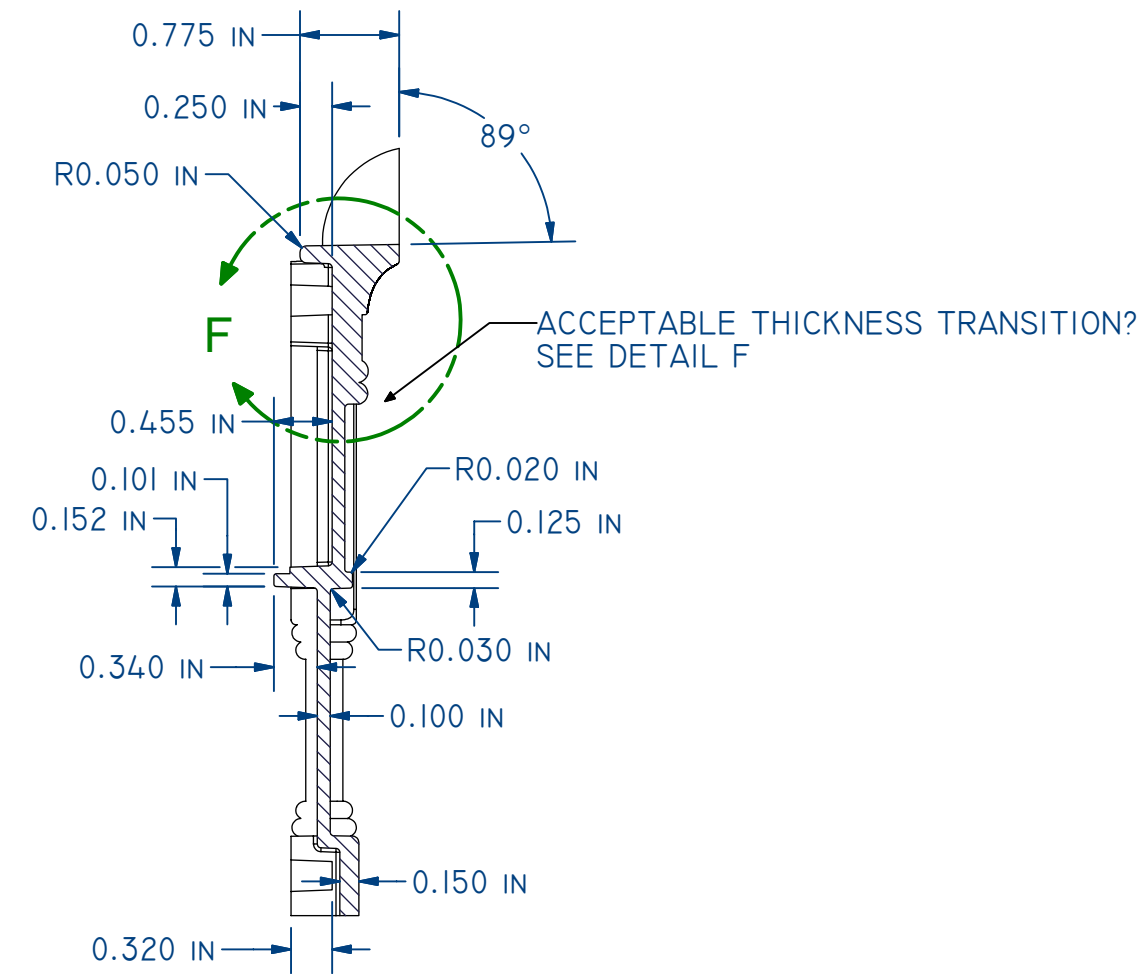
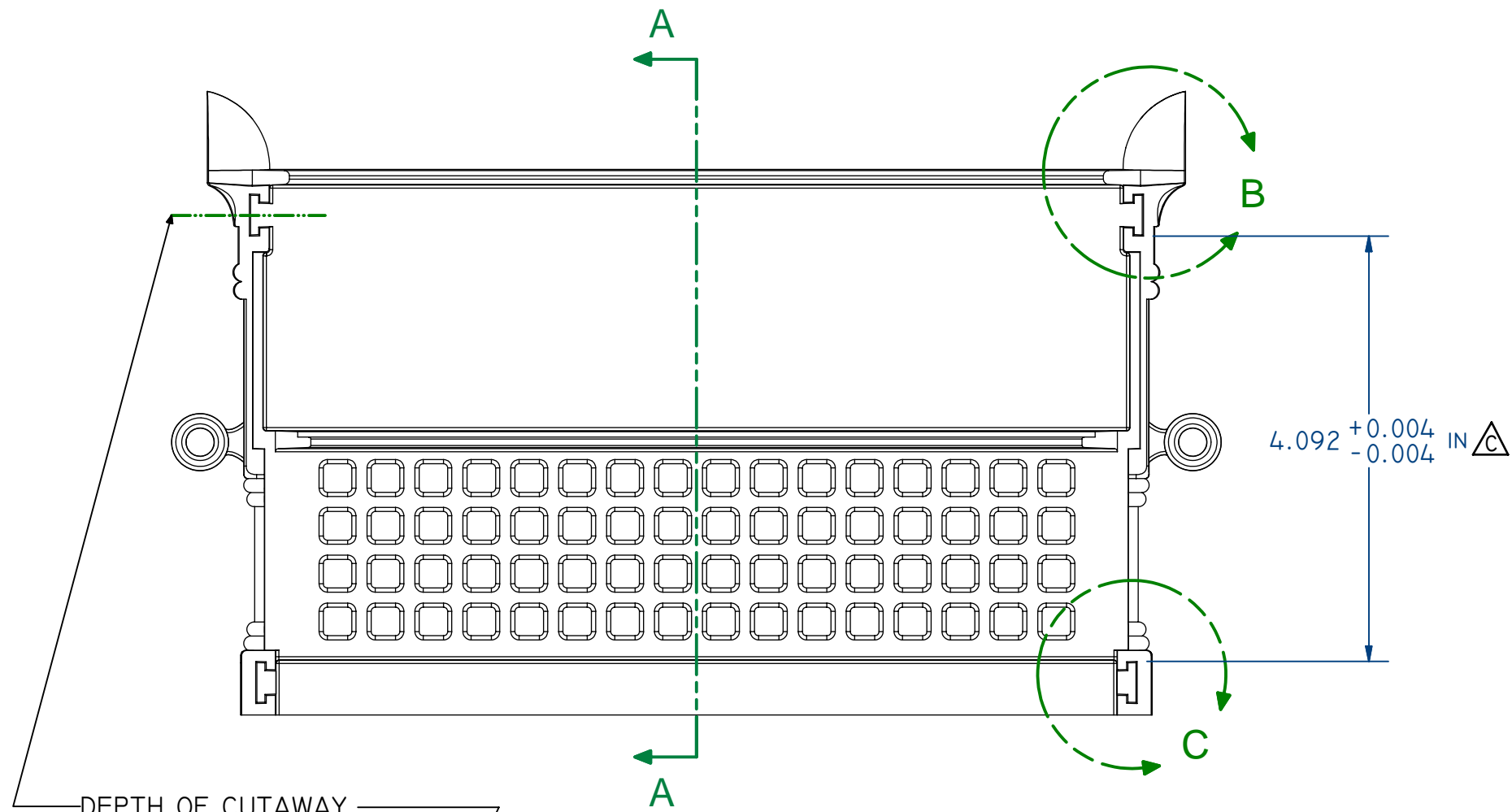

STANDARD TOLERANCES AS PER NADCA GUIDELINES UNLESS OTHERWISE SPECIFIED

- 1) +/- .010" FOR THE FIRST INCH. +/- .005" FOR EACH ADDITIONAL INCH
- 2) MIN. 1° DRAFT
- 3) TEXTURED FINISH - NOT YET SPECIFIED
- 4) .002" CLEARANCE ALLOWED FOR EACH MATING SURFACE OF CHEMICALLY BONDED MEMBERS IN ASSEMBLY (MORTISE & TENON PARTS)

△ - CRITICAL DIMENSION - NOTE: THESE ARE UNDER REVISION

VOLUME OF PART 8.887 CU. IN.

DRAWN ANDREW CROSS	3/17/2004	XYZED 3-D SOLUTIONS		
CHECKED		TITLE		
MFG		BRAZEN ALTAR - END		
APPROVED GoodSEED INT'L	3/22/2004	SIZE C	PART NO 005	REV 7
www.xyzed.ca		SCALE 2:3	SHEET 2 OF 3	

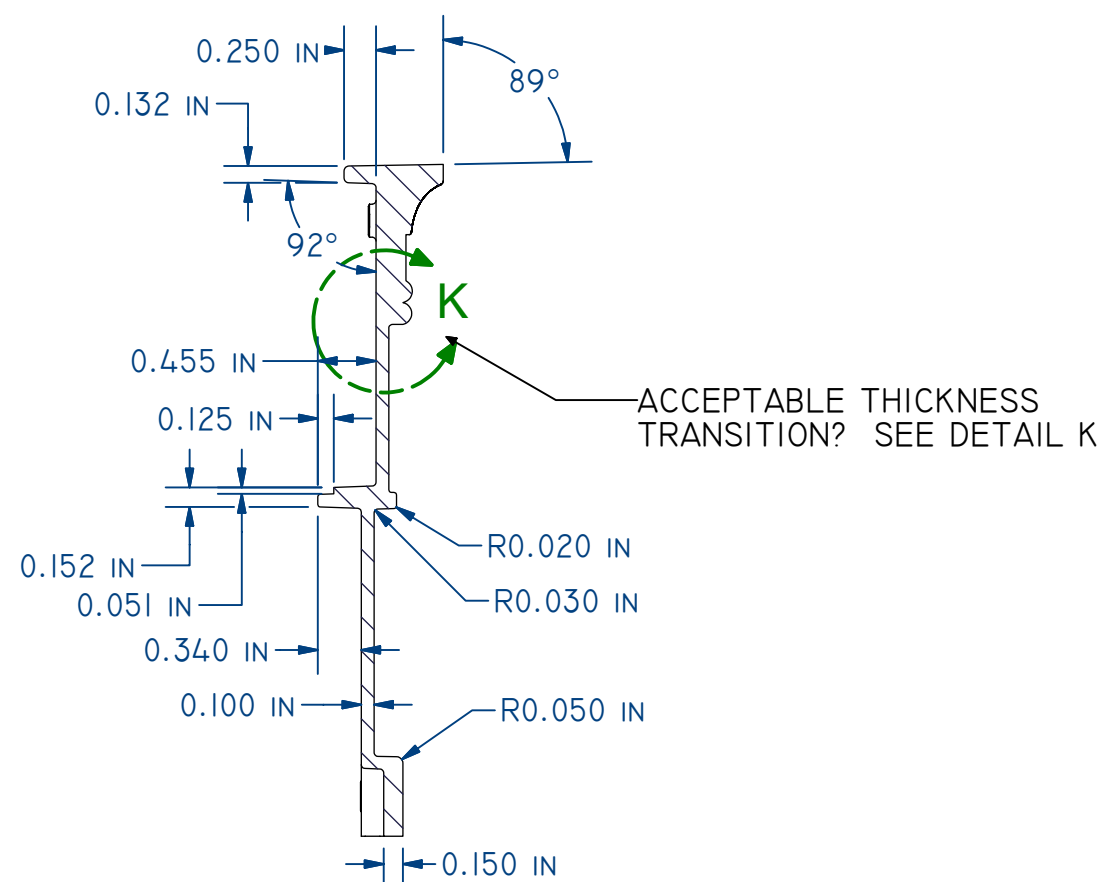
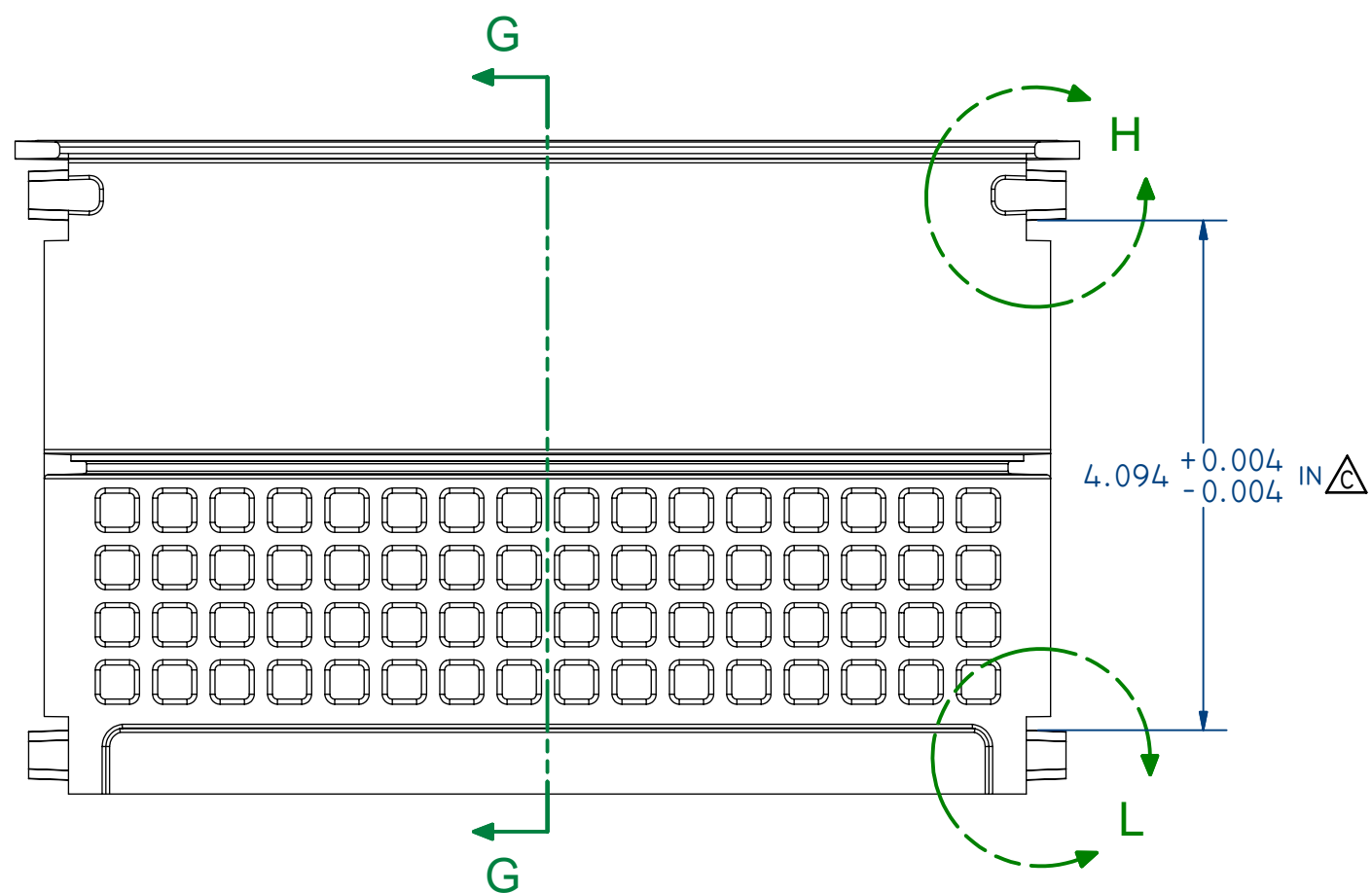

SECTION G-G
SCALE 2 / 3

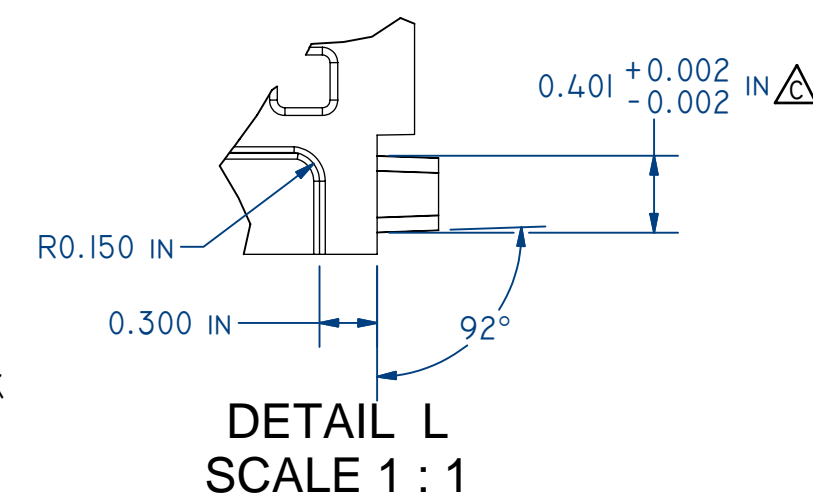

DETAIL L
SCALE 1 : 1

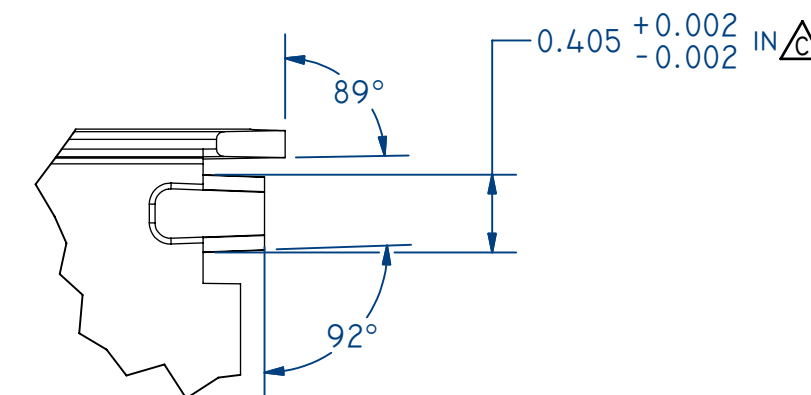

DETAIL H
SCALE 1 : 1

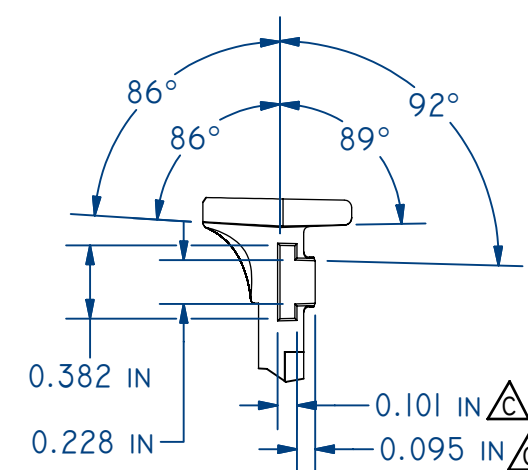

DETAIL J
SCALE 1 : 1

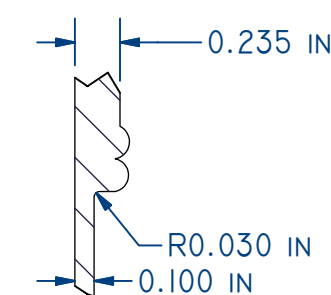

DETAIL K
SCALE 1 : 1

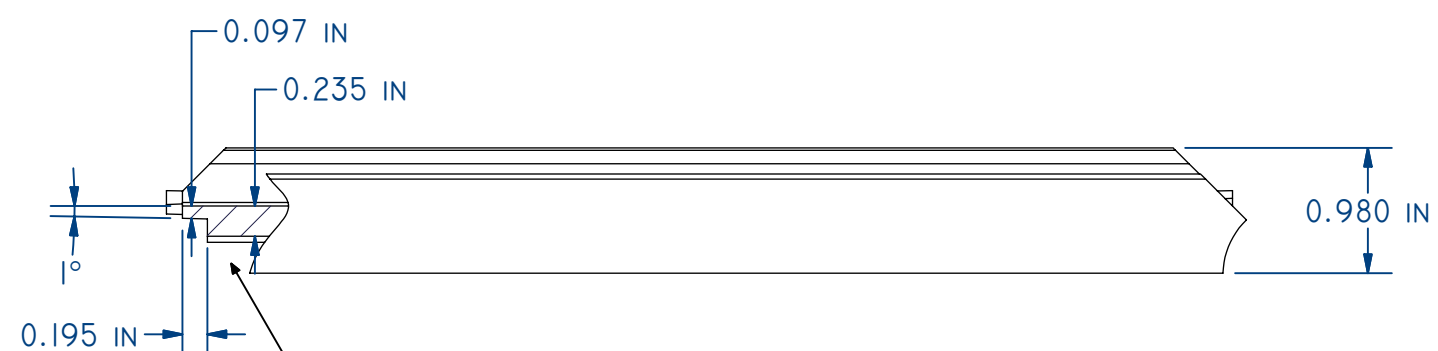

DEPTH OF CUTAWAY

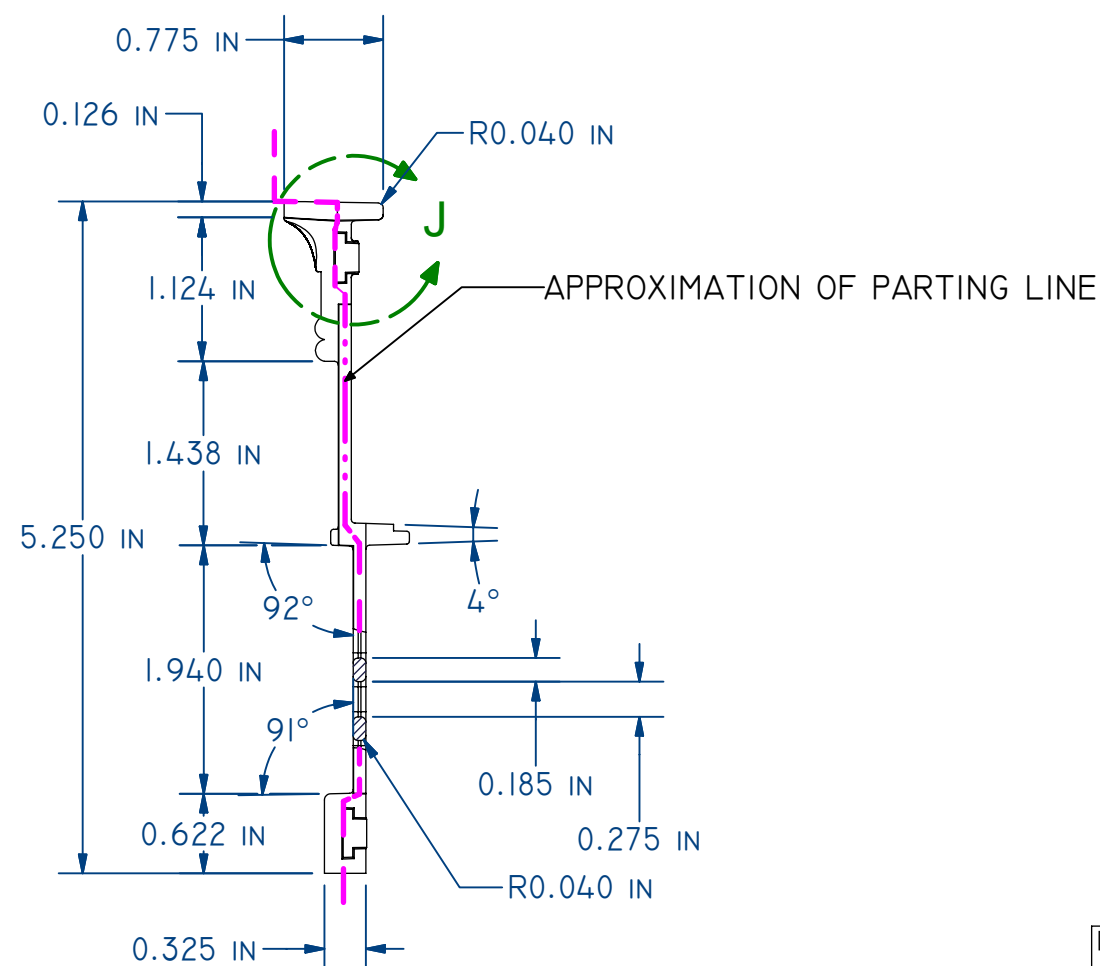
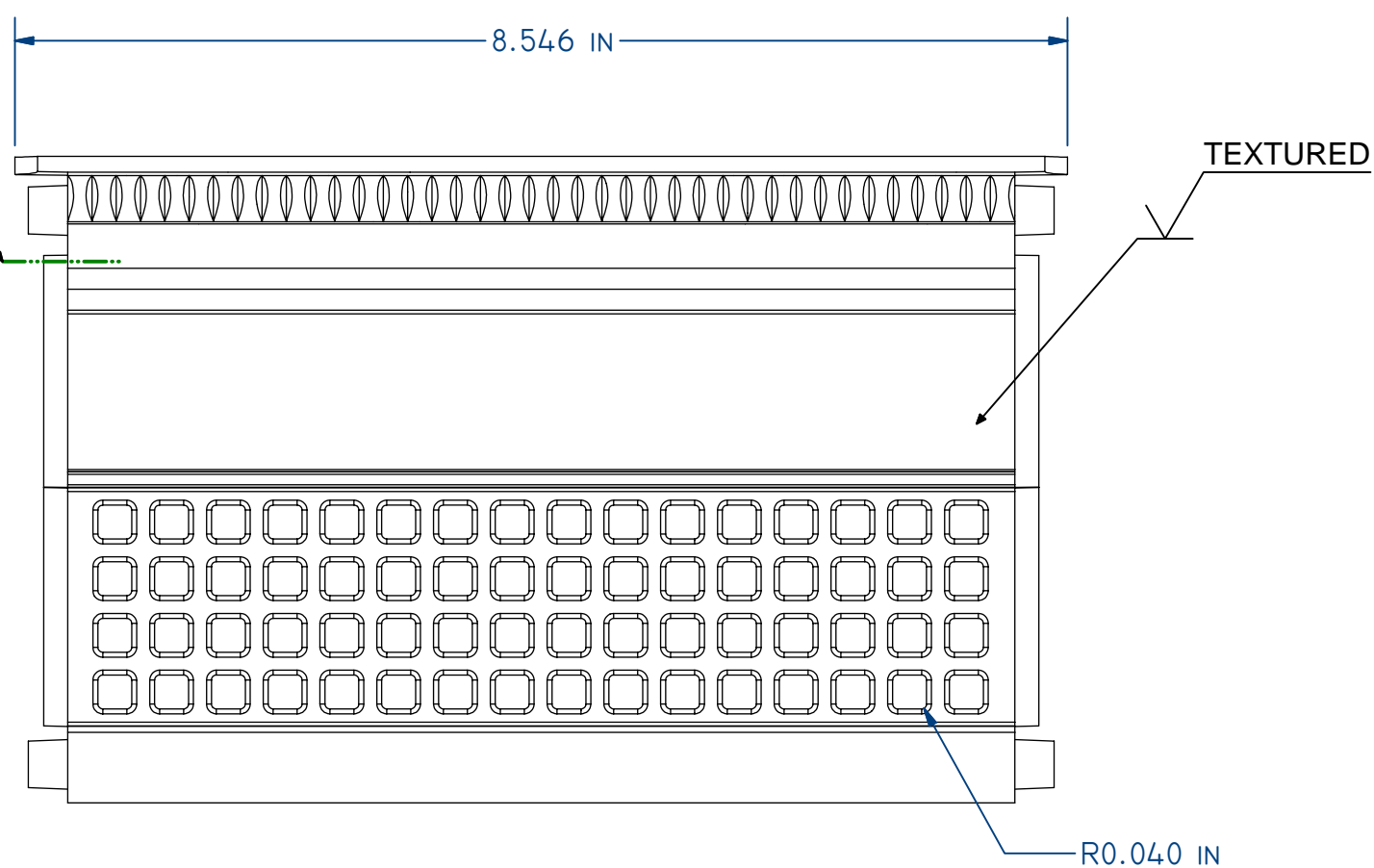

STANDARD TOLERANCES AS PER NADCA GUIDELINES UNLESS OTHERWISE SPECIFIED

- 1) +/- .010" FOR THE FIRST INCH. +/- .005" FOR EACH ADDITIONAL INCH
- 2) MIN. 1~ DRAFT
- 3) TEXTURED FINISH - NOT YET SPECIFIED
- 4) .002" CLEARANCE ALLOWED FOR EACH MATING SURFACE OF CHEMICALLY BONDED MEMBERS IN ASSEMBLY (MORTISE & TENON PARTS)

\triangle - CRITICAL DIMENSION - NOTE: THESE ARE UNDER REVISION

VOLUME OF PART - 7.113 IN³

DRAWN ANDREW CROSS	3/9/2004	XYZED 3-D SOLUTIONS		
CHECKED		TITLE		
MFG		BRAZEN ALTAR - SIDE		
APPROVED GoodSEED INT'L	3/25/2004	SIZE C	PART NO 006	REV 7
www.xyzed.ca		SCALE 2:3	SHEET 3 OF 3	

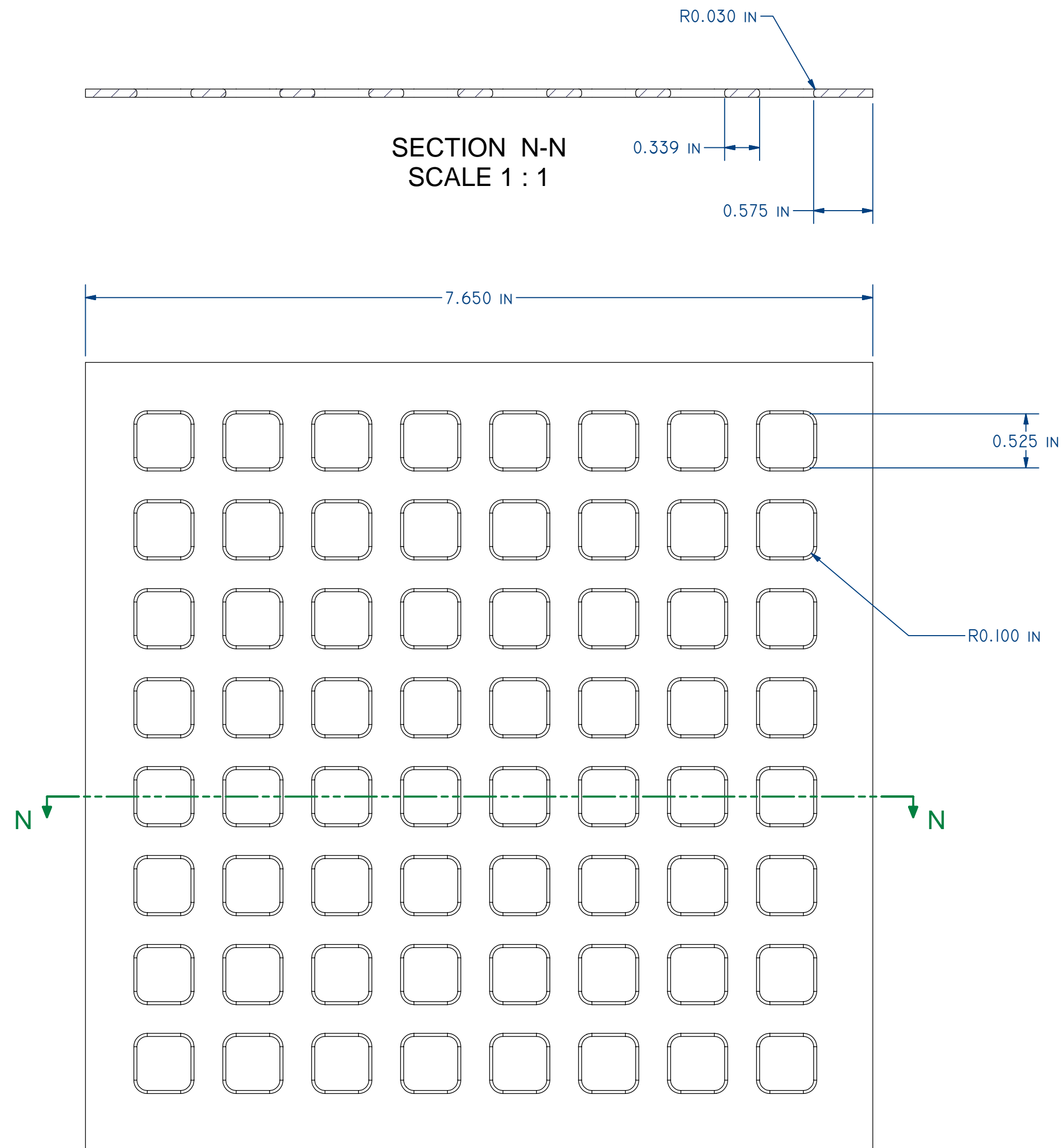

DRAWN ANDREW CROSS	3/10/2004	XYZED 3-D SOLUTIONS		
CHECKED		TITLE		
MFG		GRATE		
APPROVED		SIZE C	PART NO 007	REV 7
www.xyzed.ca		SCALE 1:1	SHEET 4 OF 4	